



URBABIL

Personaliza y combina nuestros modulos.

CALISTENIA URBABIL

El Street Workout se trata de una disciplina que se practica en la calle, para ello se han creado esta serie de circuitos formados a partir de postes horizontales y barras verticales de acero al carbono donde se permitira ejercitar todos los musculos generalmente realizando repeticiones, pero tambien de manera estatica. Barras de inox y bridas de aluminio.

Formado por modulos dedicados a diferentes actividades y ejercicios, se podran combinar de manera personalizada acorde a las necesidades de cada cliente.



Postes de INOX.

Bridas de unión de postes y barras de aluminio inyectado.

Barras de acero al carbono galvanizado imprimado y pintado.

Tornillería INOX.



La calistenia esta compuesta de postes de inox. Las bridas de unión de postes y barras son de aluminio inyectado.

Las barras son de acero al carbono galvanizado imprimado y pintado al horno en poliester y toda la tornillería en inox.

Zure proiektuan pentsatu...



Piensa en tu proyecto...

Proiektuak... Proyectos...



Astrabudua
Bizkaia



Astrabudua
Bizkaia



Astrabudua
Bizkaia



Aixerrota, Getxo
Bizkaia



Zizur Nagusia
Gipuzkoa



Sopuerta
Bizkaia



Sabino Arana, Bilbao
Bizkaia



Sabino Arana, Bilbao
Bizkaia



Sabino Arana, Bilbao
Bizkaia



Zabalparkea, Vitoria-Gasteiz
Araba



Laudio
Araba



Sopuerta
Bizkaia



PRODUKTUAK

PRODUCTOS

Barra paralelo bikoitzak Barras paralelas dobles



Dips
Dips



Flexioak
Flexiones



Oreka
Equilibrio



Trizepsak
Fondos

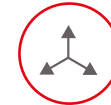

1,80x0,65x1,30m

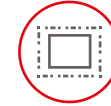

4,75x3,65m



30kg

WKOUT001G

Barra paralelo bikoitzak baxuak

Barras paralelas dobles bajas



Dips
Dips



Flexioak
Flexiones



Oreka
Equilibrio

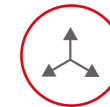

1,80x0,65x1,30m

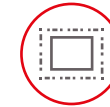

4,75x3,65m



30kg

WKOUT001GB

Barra paraleloak hirukoitzak

Barras paralelas triples



Dips
Dips



Flexioak
Flexiones



Oreka
Equilibrio



Trizepsak
Fondos

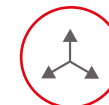

1,80x1,25x1,30m

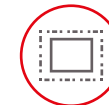

4,75x4,24m



45kg

Erabiltzaileen gutxieneko altuera

Altura mínima de usuario

+1,4m

WKOUT002G

Ariketa mahaia Mesa Workout



Oreka
Equilibrio

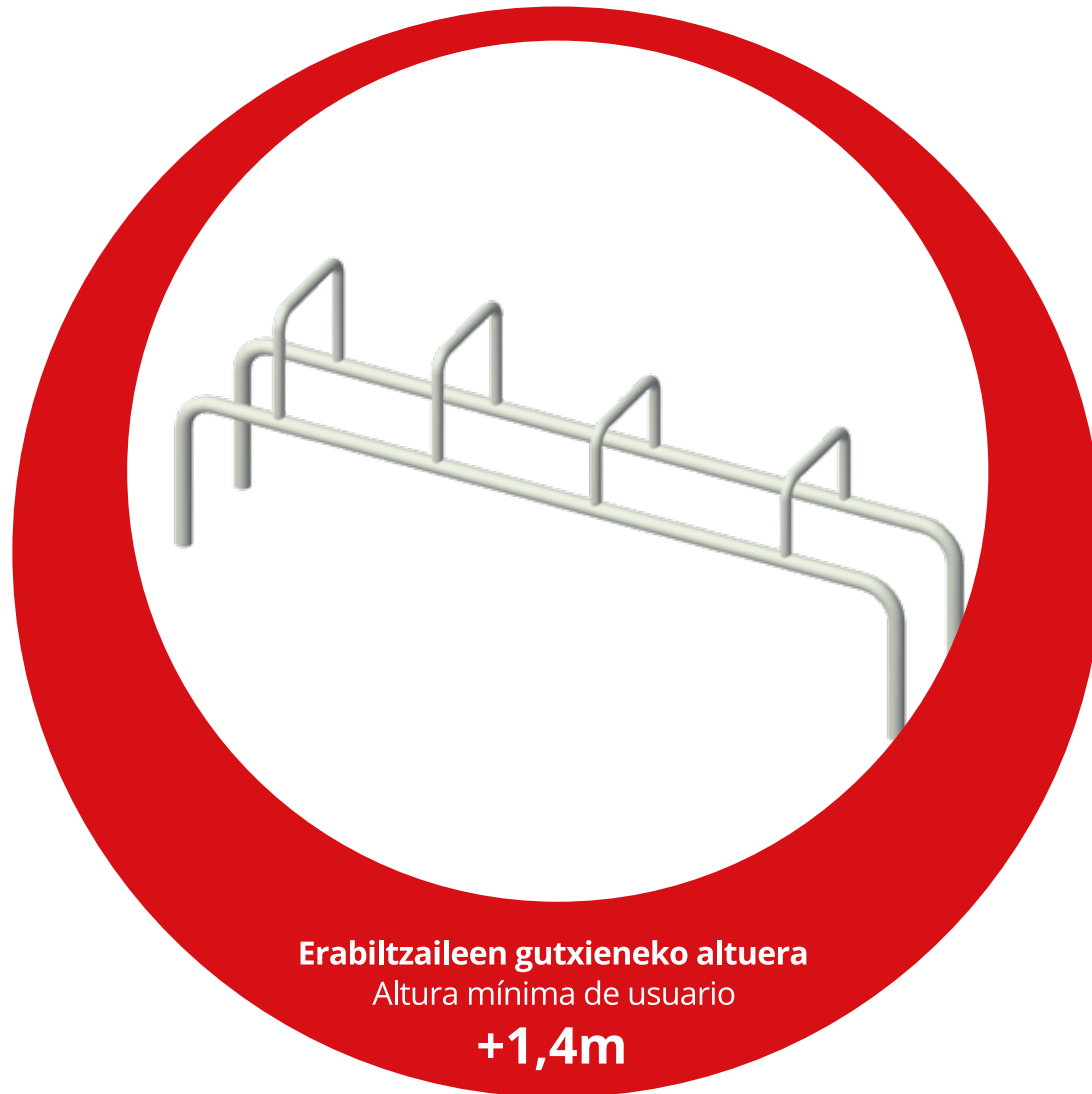

Erabiltzaileen gutxieneko altuera
Altura mínima de usuario
+1,4m

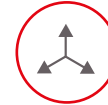

2,30x0,45x0,85m



5,25x3,45m



32kg

WKOUT003G

Dominaden barra sinplea Barra dominada simple



Dominadak
Dominadas

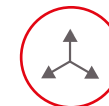

1,47x0,09x2,64m

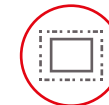

5,57x4,19m



INOX. 34kg
ISO. 47kg

Erabiltzaileen gutxieneko altuera
Altura mínima de usuario
+1,4m

WKOUT004

Dominaden barra bikoitza

Barra dominadas doble



Dominadak
Dominadas



Eskalada horizontala
Eskalada horizontal



Erabiltzaileen gutxieneko altuera
Altura mínima de usuario
+1,4m

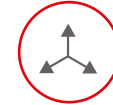

2,86x0,09x2,64m

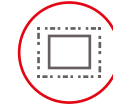

6,96x4,19m



INOX. 48kg
ISO. 69kg

WKOUT005

Dominaden barra bikoitza banderarekin

Barra dominadas doble con bandera



Dominadak
Dominadas



Eskalada horizontala
Eskalada horizontal



Bandera ariketa
Ejercicio Bandera

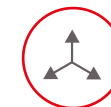

0,09x0,09x2,04m

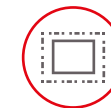

3,09x3,09m



INOX. 13kg
ISO. 20kg

Erabiltzaileen gutxieneko altuera

Altura mínima de usuario

+1,4m

WKOUT005B

Poste bertikala Poste vertical



Kukubilkatzeak
Sentadillas



Erabiltzaileen gutxieneko altuera
Altura mínima de usuario
+1,4m

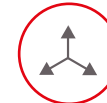

0,09x0,09x2,04m

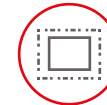

3,09x3,09m



INOX. 13kg
ISO. 20kg

WKOUT006

Hiru altuerako flexio barra

Barra de flexiones a tres alturas



Dips
Dips



Flexioak
Flexiones



Dominadak
Dominadas

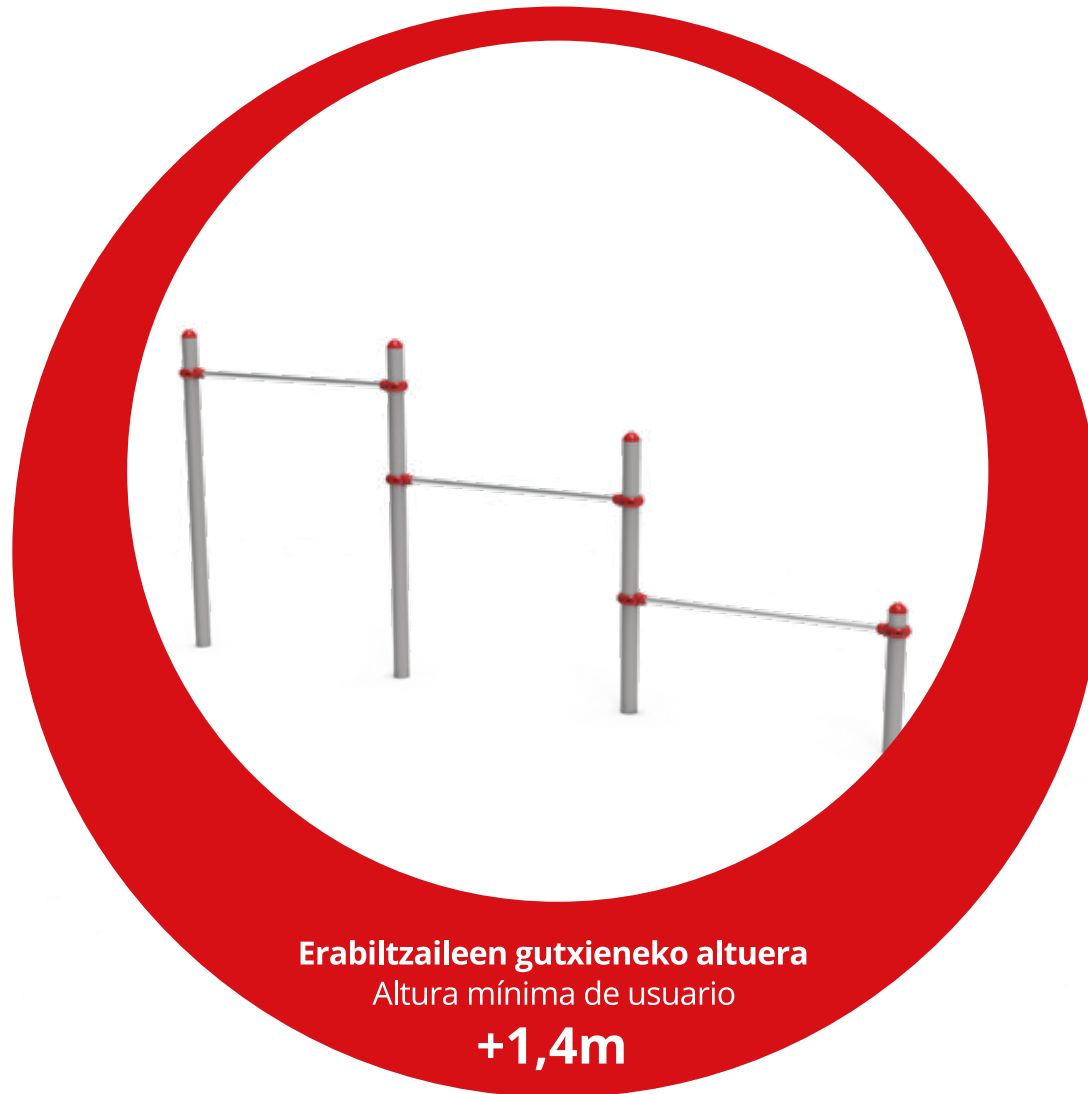

Erabiltzaileen gutxieneko altuera

Altura mínima de usuario

+1,4m

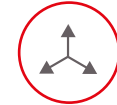

4,25x0,09x1,44m

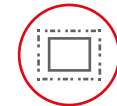

7,24x3,09m



INOX. 38kg
ISO. 51kg

WKOUT007

Eskailera horizontala

Escalera horizontal



Dominadak
Dominadas



Eskalada horizontala
Escalada horizontal

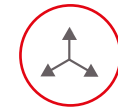
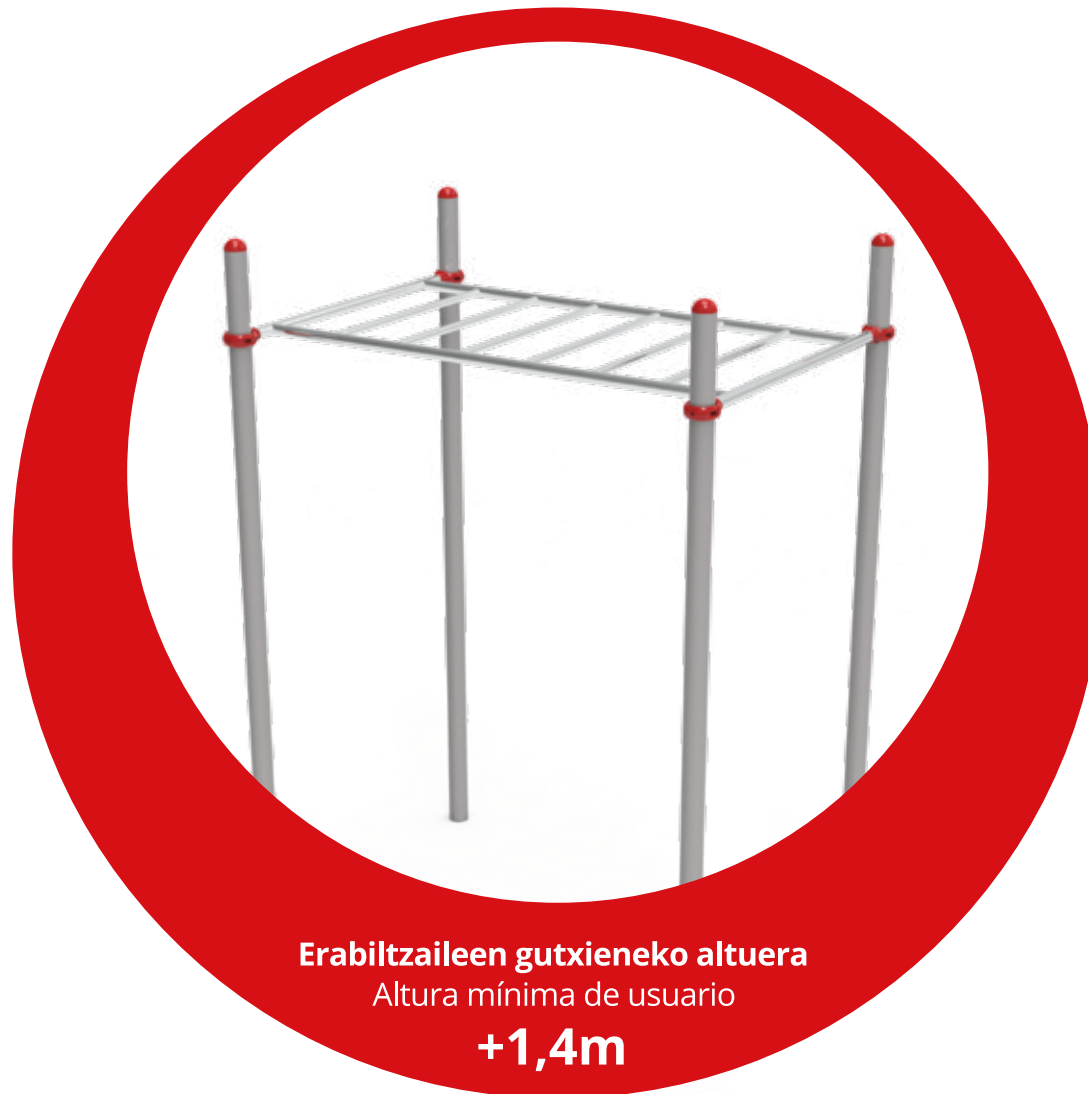

2,12x1,51x2,64m

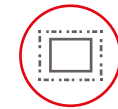

6,10x5,38m



INOX. 81kg
ISO. 110kg

Erabiltzaileen gutxieneko altuera

Altura mínima de usuario

+1,4m

WKOUT008

Abdominalen banku sinplea Banco Abdominal simple

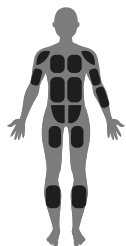

Abdominalak
Abdominales



Jauzi egin
Salto



Erabiltzaileen gutxieneko altuera
Altura mínima de usuario
+1,4m



1,70x0,74x0,49m

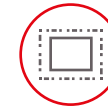

4,70x3,41m



INOX. 78kg
ISO. 84kg

WKOUT010

Abdominalen banku inklinatua, barrekin Banco abdominal inclinado con barra



Abdominalak
Abdominales



Flexioak
Flexiones

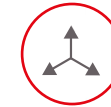

1,70x0,74x1,33m

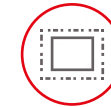

4,70x3,41m



INOX. 95kg
ISO. 106kg

Erabiltzaileen gutxieneko altuera

Altura mínima de usuario

+1,4m

WKOUT011

Abdominalen banku sinplea, barrekin

Banco abdominal simple con barra



Abdominalak
Abdominales



Jauzi egin
Salto



Flexioak
Flexiones

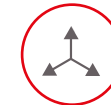

1,70x0,74x0,78m

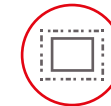

4,70x3,41m



INOX. 83kg
ISO. 92kg

Erabiltzaileen gutxieneko altuera

Altura mínima de usuario

+1,4m

WKOUT012

Barra paraleloak Barras paralelas



Dips
Dips



Flexioak
Flexiones



Dominadak
Dominadas

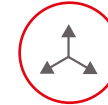

1,52x0,73x1,44m

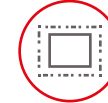

4,47x3,69m



INOX. 40kg
ISO. 54kg

Erabiltzaileen gutxieneko altuera
Altura mínima de usuario
+1,4m

WKOUT014

Barra paralelo bikoitza

Barra paralelas dobles

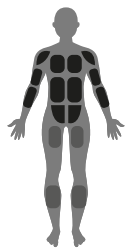

Dips
Dips



Flexioak
Flexiones



Oreka
Equilibrio



Trizepsak
Fondos



Erabiltzaileen gutxieneko altuera
Altura mínima de usuario

+1,4m

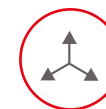

2,90x0,73x1,44m

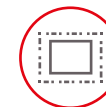

5,85x3,69m



INOX. 63kg
ISO. 83kg

WKOUT015

Egokitutako barra paralelo bikoitza

Barra paralelas dobles adaptada



Dips
Dips



Flexioak
Flexiones



Oreka
Equilibrio



Trizepsak
Fondos



Erabiltzaileen gutxieneko altuera
Altura mínima de usuario
+1,4m



2,90x0,73x1,44m

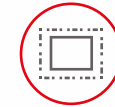

5,85x3,69m



INOX. 63kg
ISO. 83kg

Calistenia Inclusiva



WKOUT015-AD

Eskailera bertikala

Escalera vertical



Kukubilkatzeak
Sentadillas



Horma-barra
Espaldera



Hankak goratu
Elevación
de piernas

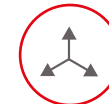

1,48x0,09x2,64m

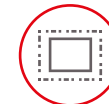

5,57x4,19m



INOX. 57kg
ISO. 71kg

Erabiltzaileen gutxieneko altuera

Altura mínima de usuario

+1,4m

WKOUT016

Suge barra Barra serpiente



Dominadak
Dominadas



Eskalada horizontala
Eskalada horizontal

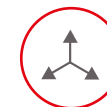

2,13x0,60x2,64m

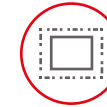

6,20x4,68m



INOX. 46kg
ISO. 61kg

Erabiltzaileen gutxieneko altuera
Altura mínima de usuario
+1,4m

WKOUT017

Uztaien barra Barra de anillas



Dominadak
Dominadas



Eskalada horizontala
Escalada horizontal



Uztaiak
Anillas

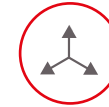

1,52x0,09x2,74m

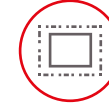

5,12x3,73m



INOX. 36kg
ISO. 50kg

WKOUT018

Dominaden barra, hiruki formakoa Barra de dominadas triangular

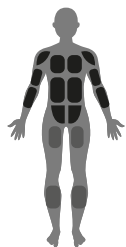

Dominadak
Dominadas

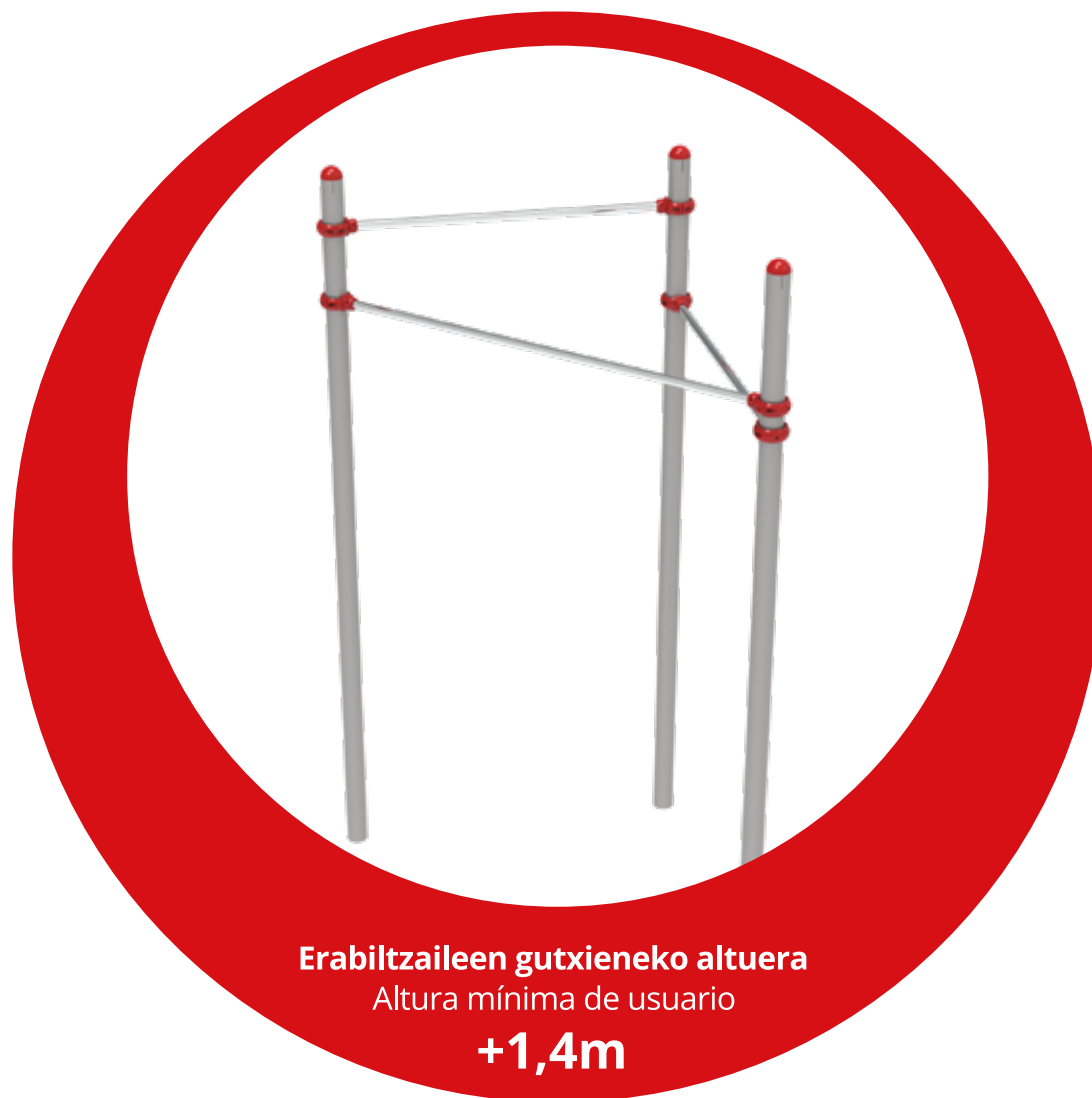

Erabiltzaileen gutxieneko altuera
Altura mínima de usuario
+1,4m

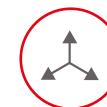

1,58x1,74x2,64m

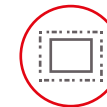

5,79x5,55m



INOX. 57kg
ISO. 78kg

WKOUT019

Pull Up Dominaden barra Barra dominadas Pull Up

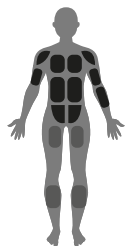

Dominadak
Dominadas



Eskalada horizontala
Eskalada horizontal

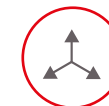
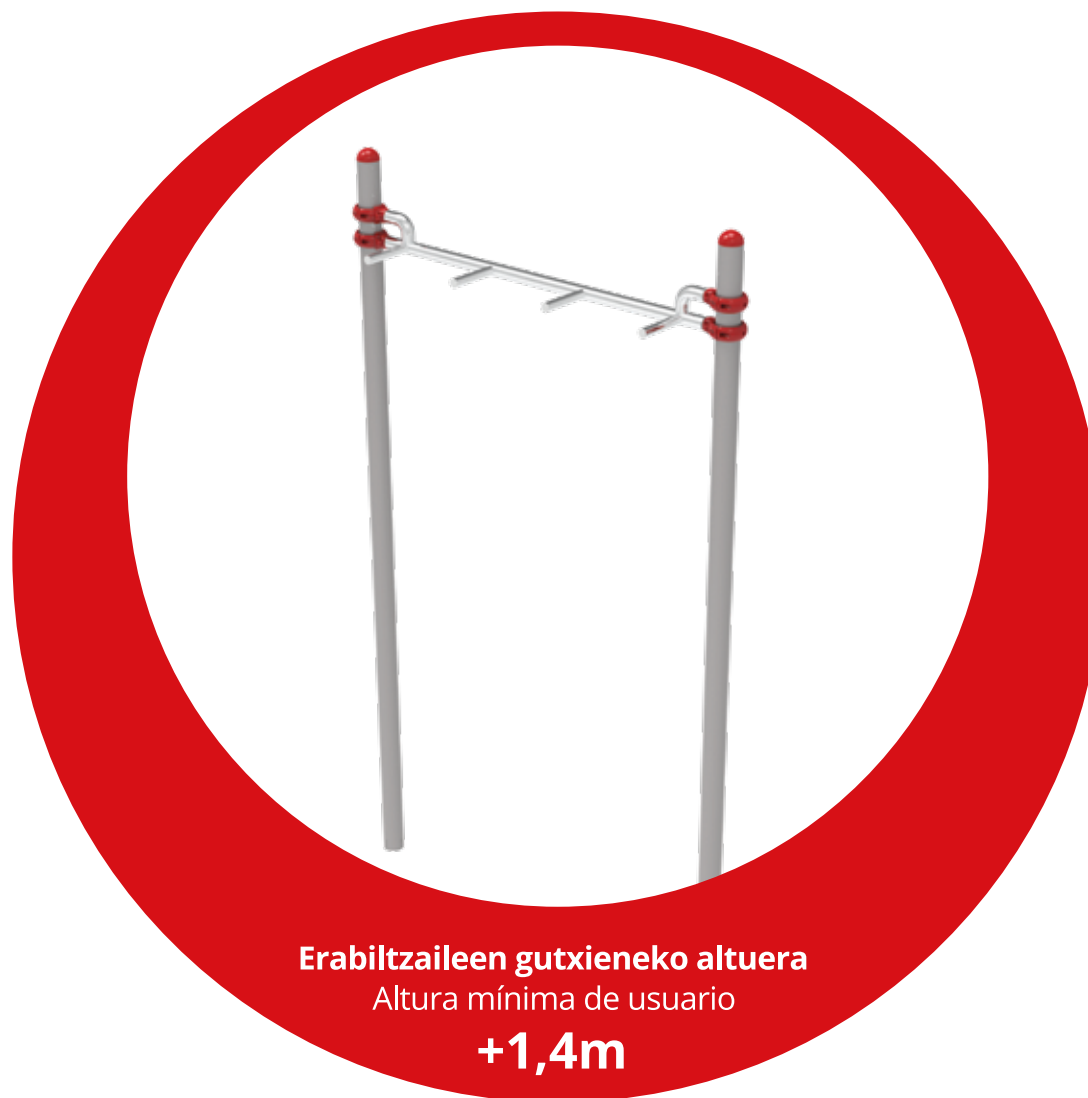

1,82x0,49x2,64m

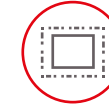

5,42x4,14m



INOX. 35kg
ISO. 49kg

Erabiltzaileen gutxieneko altuera

Altura mínima de usuario

+1,4m

WKOUT020

Saltorako multzoa

Conjunto de salto

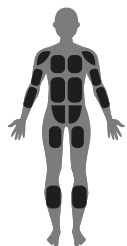

Flexioak
Flexiones



Jauzi egin
Salto



Erabiltzaileen gutxieneko altuera
Altura mínima de usuario
+1,4m

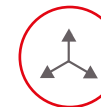

2,73x1,70x2,,m



5,49x5,15m



INOX. 210kg
ISO. 230kg

WKOUT021

Eskailera bertikala eta barren multzoa Conjunto escalera vertical y barras

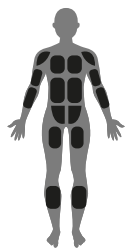

Kukubilkatzeak
Sentadillas



Horma-barra
Espaldera



Dominadak
Dominadas



Hankak goratu
Elevación
de piernas

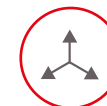

1,51x1,51x2,64m

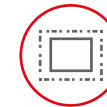

5,58x5,58m



INOX. 90kg
ISO. 119kg

Erabiltzaileen gutxieneko altuera
Altura mínima de usuario
+1,4m

WKOUT101

Eskailera bertikala bikoitza eta barren multzoa

Conjunto escalera doble vertical y barras



Kukubilkatzeak
Sentadillas



Horma-barra
Espaldera



Dominadak
Dominadas



Hankak goratu
Elevación
de piernas

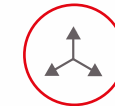

1,51x1,51x2,64m

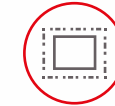

5,58x5,58m



INOX. 90kg
ISO. 119kg

Erabiltzaileen gutxieneko altuera

Altura mínima de usuario

+1,4m

WKOUT101 DOBLE

Abdominaletako bankuak Bancos abdominales



Abdominalak
Abdominales



Flexioak
Flexiones



Dominadak
Dominadas

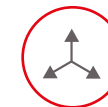

2,73x1,70x2,,m

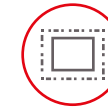

5,49x5,15m



INOX. 210kg
ISO. 230kg

Erabiltzaileen gutxieneko altuera
Altura mínima de usuario
+1,4m

WKOUT102

Abdominaletako bankuak

Bancos abdominales



Abdominalak
Abdominales



Flexioak
Flexiones



Dominadak
Dominadas

Calistenia Inclusiva



Erabiltzaileen gutxieneko altuera
Altura mínima de usuario
+1,4m

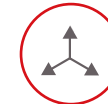

2,73x1,70x2,,m

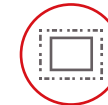

5,49x5,15m



INOX. 210kg
ISO. 230kg



WKOUT102COMB

Bi eskailera horizontalen multzoa Conjunto dos escaleras horizontales



Dominadak
Dominadas



Eskalada horizontala
Escalada horizontal

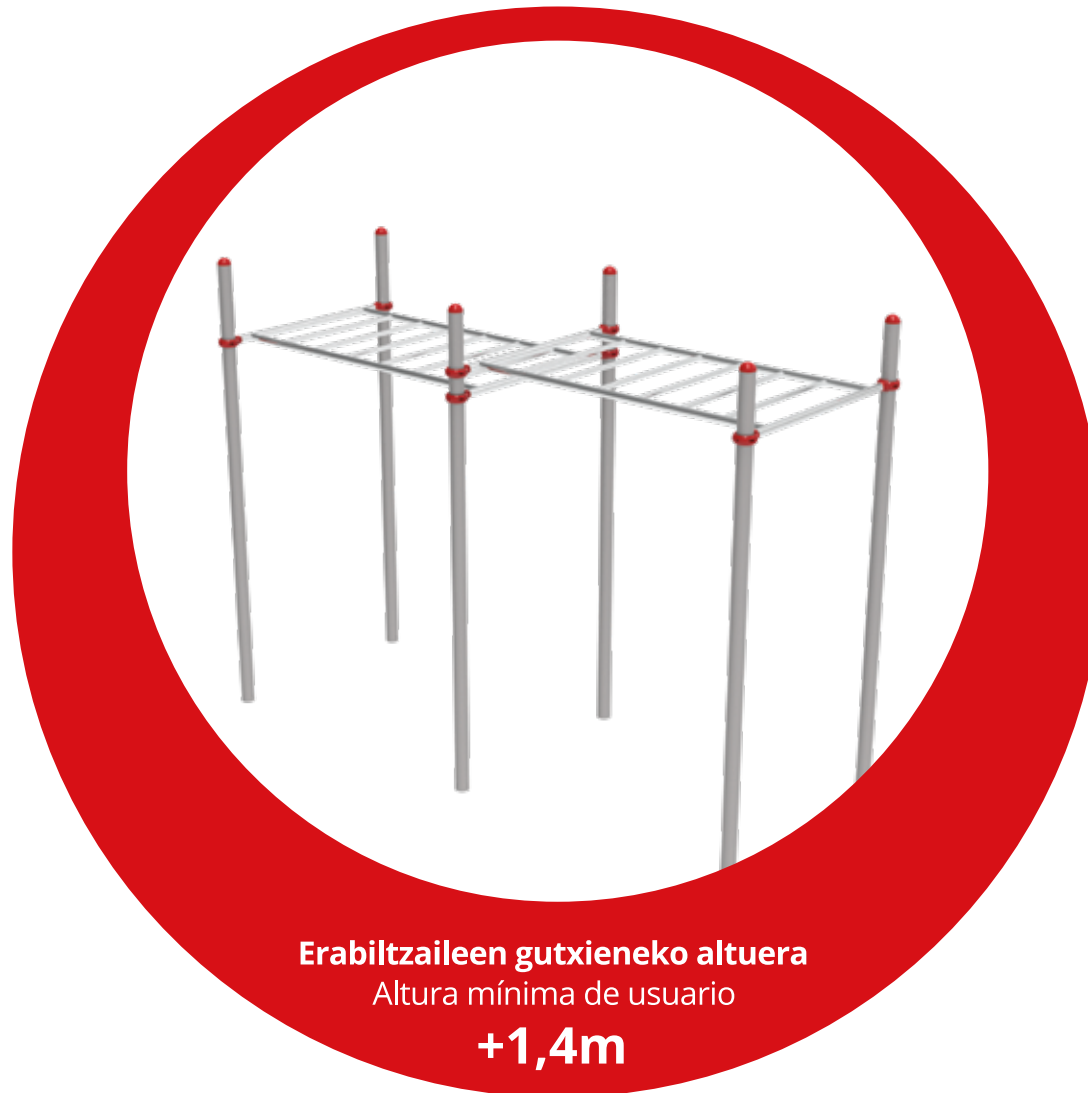

Erabiltzaileen gutxieneko altuera

Altura mínima de usuario

+1,4m

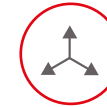

4,12x1,51x2,64m

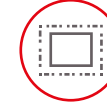

8,08x5,38m



INOX. 133kg
ISO. 176kg

WKOUT103

Egokitutako eskailera multzoa banderarekin

Conjunto escaleras adaptada con bandera



Dominadak
Dominadas



Eskalada horizontala
Escalada horizontal



Bandera ariketa
Ejercicio Bandera



Calistenia Inclusiva

Erabiltzaileen gutxieneko altuera
Altura mínima de usuario
+1,4m



6x1,51x2,64m

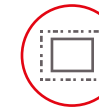

8,08x5,38m



INOX. 133kg
ISO. 176kg



WKOUT103AD-B

Hiru eskailera multzo eta bat egokituta

Tres conjuntos de escaleras y una adaptada

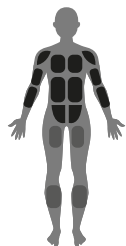

Dominadak
Dominadas



Eskalada horizontala
Escalada horizontal

Calistenia Inclusiva

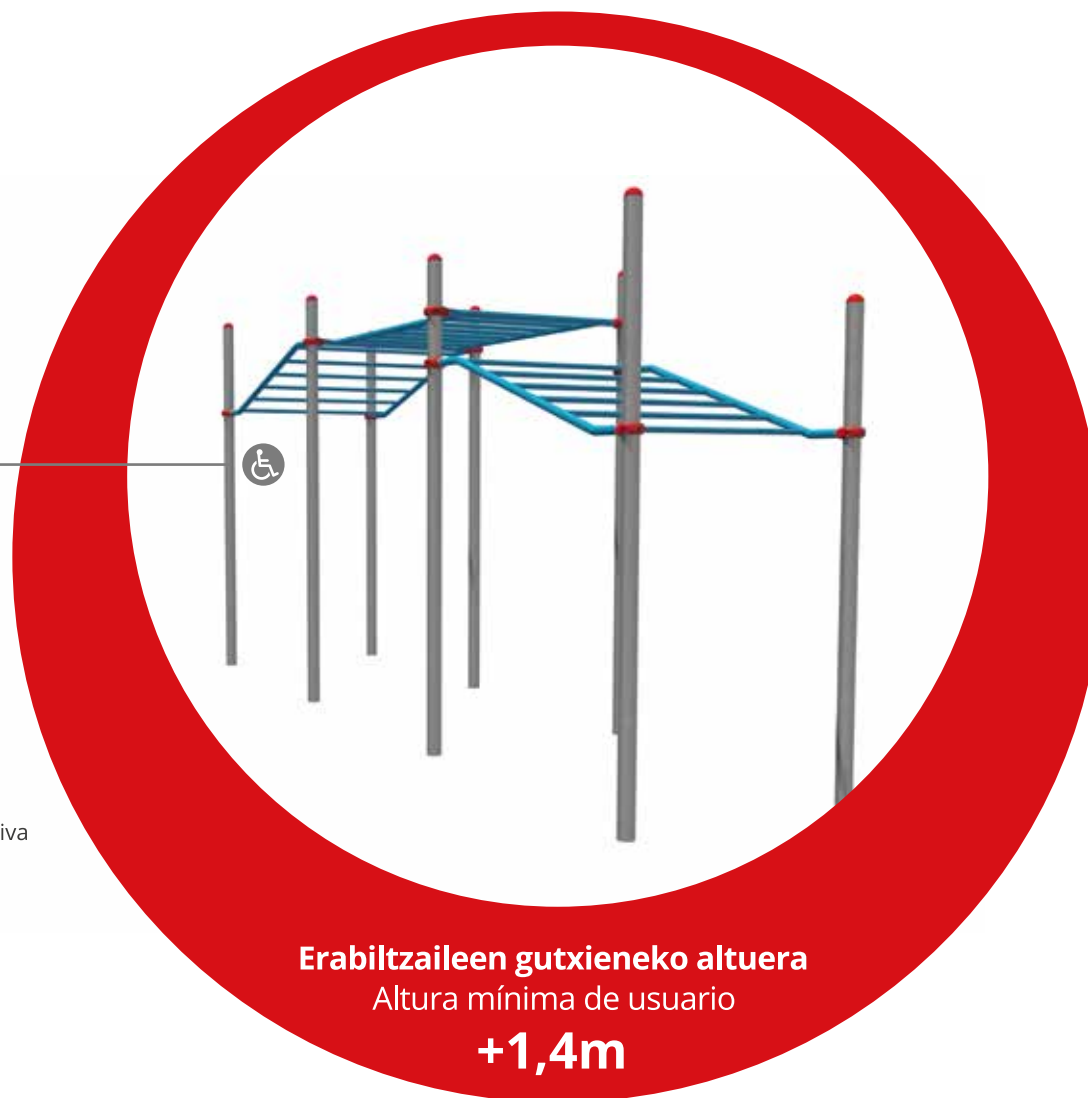

Erabiltzaileen gutxieneko altuera
Altura mínima de usuario
+1,4m



6x1,51x2,64m

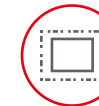

8,08x5,38m



INOX. 133kg
ISO. 176kg



WKOUT103-3-AD

Dominaden multzoa, eskailera eta barrekin

Conjunto dominadas con escalera y barras

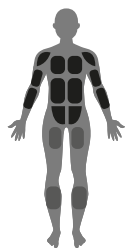

Dominadak
Dominadas



Eskalada horizontala
Escalada horizontal



Erabiltzaileen gutxieneko altuera
Altura mínima de usuario
+1,4m



8,27x2,44x2,64m

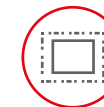

12,34x5,78m



INOX. 224kg
ISO. 309kg

WKOUT104

Saltorako hiru plataforma Tres plataformas de saltos

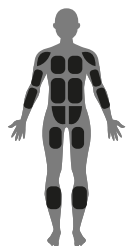

Abdominalak
Abdominales



Jauzi egin
Salto



Erabiltzaileen gutxieneko altuera
Altura mínima de usuario
+1,4m



2,73x1,70x2,,m



5,49x5,15m



INOX. 210kg
ISO. 230kg

WKOUT108



Certificado de diseño: Cd DBD 750 240308.188

Los elementos de gimnasia de acceso libre "188" de URBABIL 2000, S.L. con presencia de *Banco de abdominales, Barras paralelas y Estación de Calistenia con barras de flexiones, barras dominadas, anillas de ejercicio, banco de abdominales, espaldera y barras de braquiación;*



Con base a la evaluación realizada, a partir de la documentación técnica presentada el 08 de marzo de 2024 e inspecciones realizadas en una instalación a finales de noviembre de 2022, se considera:

CONFORME*

Con los requisitos de diseño aplicables y evaluables de las Normas
UNE-EN 16630: 2015

Y para que conste, firmo en representación de **ASES XXI, S.L.**

Fecha de certificación: **08 de marzo de 2024.**

CERTIFICADO DE DISEÑO

Cd DBD 750 240308.188



* Para la emisión de los certificados definitivos de cumplimiento de las Normas UNE-EN 16630:2015, será imprescindible realizar una inspección "in situ" del área y las estructuras instaladas y realizar las pruebas de atenuación de impacto en pavimento sintético de amortiguación comprobando según Método 2 de la Norma UNE-EN 1177:2018+AC Mayo 2019.



URBABIL

 94 674 20 90

 urbabil@urbabil.es

Kontaktuan jarri... Contacta...

www.urbabil.es



Urbabil S.L. • @urbabil_empresa • @urbabil • urbabil_empresa

